

PROBE TIPS #4

A Technical Bulletin for Probing Applications

Probing GaAs Devices and High Frequency/Speed Devices

Gallium Arsenide devices have brought new testing challenges to the emerging GaAs industry. GaAs device demand and production has been primarily driven by the military and telecommunications segments of the world electronics market. GaAs offers these consumers significantly increased speed (up to 30 times faster) as compared to conventional silicon devices. The military segment finds GaAs devices particularly attractive because of their ability to withstand radiation dosages far beyond their silicon counterparts. The high speed and radiation resistance for military applications assures dramatic growth for GaAs technology well into the next century. New test methods and probe fixtures are emerging to respond to these new test challenges.

DELICACY IN PROBING (CONTACT PRESSURE)

GaAs is an extremely brittle material and subject to fracturing as a result of the inability of the material to handle normal contact forces. Contact Pressure is defined as:

$$\text{Contact Pressure} = \frac{\text{TipForce}\{\text{Grams}\}}{\text{TipArea}\{\text{Mils}\}}$$

The probe tip area obviously has a large impact on contact area. A change in tip area from 2 mils to 3 mils (by wear for example) will decrease the contact pressure by 50%, assuming all other parameters are held constant. Typically, select a probe tip size of no less than ½ the pad area to be contacted.

GaAs devices typically have 2 mil to 4 mil (50µm to 100µm) bond pads and therefore would typically require 1 mil or 2 mil diameter tips respectively.

Tip Force is a function of several variables including prober overdrive, probe needle material type and size and the beam length of the needle. Prober overdrive is the major contributing factor to tip force increasing linearly with overdrive. However, probe planarity will have a considerable impact on the amount of overdrive of a particular needle. Overdrive should typically not exceed 2 mil when probing GaAs devices.

Planarization is absolutely critical if minimal overdrive is used. Planarization is defined as the relative position of the probe tips in relation to a reference plan. Perfect planarization assumes that all contact points make simultaneous contact with the device under test. Probe to probe planarization can and should be held within a tolerance of 1/100. 2 mils (5 microns). Z Adjustable probes are particularly well suited for precision planarization control when used with planarization instrumentation designed for the job. Precision planarization provides uniform contact pressure, which results in uniform contact resistance.

Figure#1

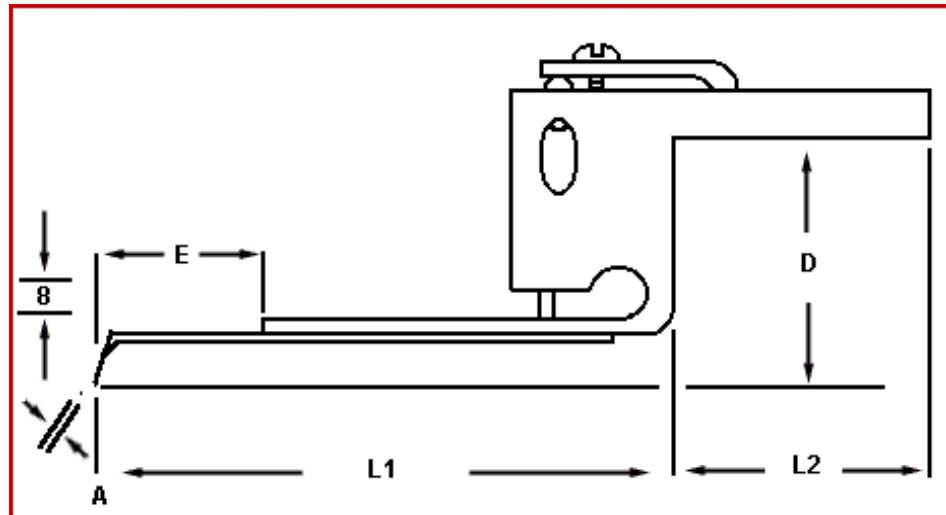

Needle material type influences tip force due to the relative stiffness of the material. Tungsten is much stiffer than Beryllium Copper (BeCu) given the same needle size. Therefore, BeCu will provide a typically lower contact force per mil of overdrive. BeCu, however, is the best material for other reasons when probing GaAs devices with little overdrive. Contact resistance is considerably lower than that of tungsten. BeCu, although a softer material, will exhibit comparable life to tungsten if planarization and overdrive are tightly controlled. BeCu tends to clean itself as the probe wears and is far less likely to build up contamination causing high contact resistance. Bond pads on GaAs devices are most commonly gold because of its better conductive properties and higher resistance to oxidation of the pad surface area. BeCu should always be used to probe gold pads. Tungsten should not be used because its inherent higher and varying contact resistance compromises the test accuracy typically required of high reliability components.

Needle shaft (Beam) size and length affect tip force. Cantilever beam theory defines beam length as the distance from a probe fulcrum point (probe body) to the tip. We refer to it as dimension "E" or tip extension (see Fig.1). The shorter the beam length the greater the probe tip force for a given needle material. Needle diameter clearly impacts the tip force and determines the flex of the beam for a given material. Typically, smaller diameter needles and longer extensions are selected when probing GaAs devices to reduce tip force and resulting device damage. However, beam length also becomes a contributing electrical factor where the needle becomes an electrical performance component whereby shorter beam length provides lower inductance and capacitance. The needle ultimately selected will usually represent a reasonable compromise between all these conflicting variables.

Delicacy seems to be the right word to convey the need to precisely control the physical dynamics of probing GaAs devices. The degree to which these elements are controlled will directly affect the degree of success and the yield achieved.

High Speed/Frequency Test Considerations

GaAs devices are pushing the limits increasing both frequencies and test speeds. Frequency ranges for GaAs devices are now routinely in excess of 100MHz and pushing the state of the art to 40GHz. Test speeds range from 10pS to 1nS. Probe card technology has struggled to keep up with these increasing frequencies and speeds. The card styles and connectors, which are required, are changing the character of the probe industry from off the shelf generic probe cards to application specific custom probe card designs.

CUSTOM CARDS

To design a high-frequency probe card means bridging the traditional separation of conceptual design and physical implementation. In these applications, physical layout is intimately associated with circuit performance and the test results obtained.

The device design engineer, the production test engineer and the probe card designer must collaborate to achieve the best possible design.

In designing the high frequency probe card, the designer will have to take into consideration the geometric features of the physical layout. Etch length, width, thickness, spacing, via placement and corners all have a direct effect on performance.

Ground planes are used extensively both as inner layers and on the external surface of the card. The external ground plane often serves as an EMI shield and provides a means for attaching a coax shield for improved grounding. The inner ground plane also can serve as a common ground and reduce capacitive coupling between traces on either side of the board. Most importantly, the inner ground plane serves to provide more accurate control of characteristic impedance. The value of characteristic impedance depends mainly on the width of the trace conductor and its distance from the ground plane(s). The ability of multilayer probe cards to provide transmission line characteristics has resulted in their becoming increasingly valuable in high-speed applications.

There are two basic approaches to controlling impedance on multilayer probe cards. These are microstrip and stripline construction.

In stripline construction the ground plane is above and below the signal line. Microstrip construction is when the ground plane is either above or below the signal line. Figure 2 and 3 illustrate microstrip and stripline construction.

Figure #2

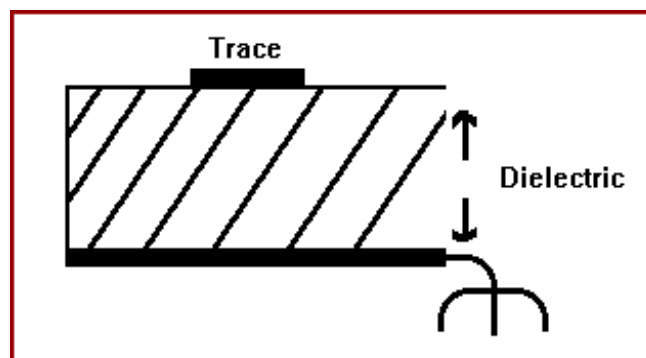

Ringings is the term used when impedance mismatch between lines causes reflections. When a pulse reaches the end of a line at a load, connector, or when a line splits reflection and scattering occurs. Subsequently, a further reflection occurs when the pulse returns to the input. One can visualize the effect by recalling the high school physics lab wave tank where a liquid is reflected back and forth through the tank. Crosstalks resulting from mismatch, the resulting reflections and the proximity of traces is accumulative with the reflecting signal destroying the signal integrity with each pass.

Figure #3

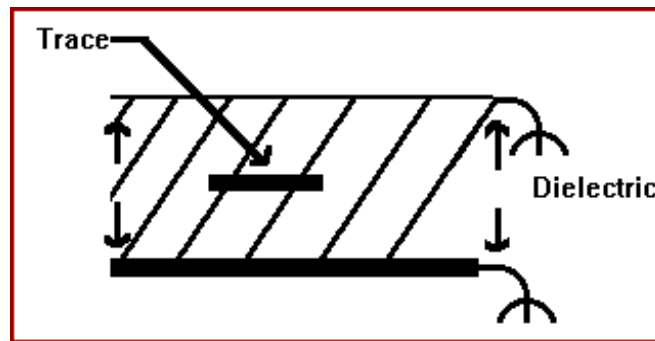

It can clearly be seen from the above information that the solution to successful probing of a high frequency, high speed GaAs device will most likely come from a cooperative effort between the device designer, the production test engineer and the probe card design specialist. Custom design, application specific, probe cards offer the best opportunity for success.

PROBES

The preceding information gives a very clear picture of the complexity of assuring signal integrity through the probe card. The probe, however, represents the business end of the test fixture and is no less constrained to contact and transfer the signal without signal loss or degradation.

There are several probe technologies in use today which will to a greater or lesser degree be suitable for probing high speed GaAs devices. The key performance characteristics to consider are planarization accuracy and its effect on contact force and contact resistance, probe to probe capacitance for reduced crosstalk and the ability to maintain signal integrity through the probe to the bond pads.

Epoxy Ring – This technology offers low capacitance from probe to probe and generally performs well. However, because of the design of most epoxy ring probes, contact pressure is not uniform from probe to probe due to varying beam length which is necessary to contact various device geometries. Additionally, planarization is difficult to maintain because each needle must be pushed or pulled with tweezers. Generally, planarization of ± 7 mils ($18\mu\text{m}$) is achievable although ± 35 ($9\mu\text{m}$) could be possible with considerable time and effort.

Metal Blades- The high capacitance from blade to blade makes this probe less desirable. AC Guarding techniques with adjacent traces and probes terminated to ground will greatly minimize crosstalk. Blade probes do offer controlled and uniform contact pressure but again planarization must be maintained with push pull techniques.

Ceramic Blades- These are similar to metal blades in terms of physical properties- Microstrip capability provides enhanced electrical characteristics. They have the same planarization limitations as metal blades.

Z Adjustable- these probes have high capacitance from probe to probe unless AC guarding techniques are used with adjacent traces terminated to ground. They provide uniform contact pressure due to equal beam lengths.

The Z adjustable feature allows precision control of planarization to within $\pm .2$ mil ($5\mu\text{m}$) and permits convenient planarization maintenance.

Z Adjustable Ceramic- These probes combine the benefits of Ceramic blade probes with those of Z adjustable. The ceramic portion of the probe provides the microstrip construction and serves to hold a single needle or dual co-planer needles.

Given all of the considerations above, device designers today are designing in ground pads in many devices to provide co-planer "AC Guarding" of the signal line as the signal passes through the needle tips.

A unique solution to solve both mechanical and electrical requirements comes from an adjustable probe with a ceramic needle holder with microstrip construction and miniature coaxial cable transmission line which connects to the via in the probe card. Those devices without co-planer bond pads can still benefit from the AC guarding at least down to where the probe needle exits the microstrip.

Figure #4

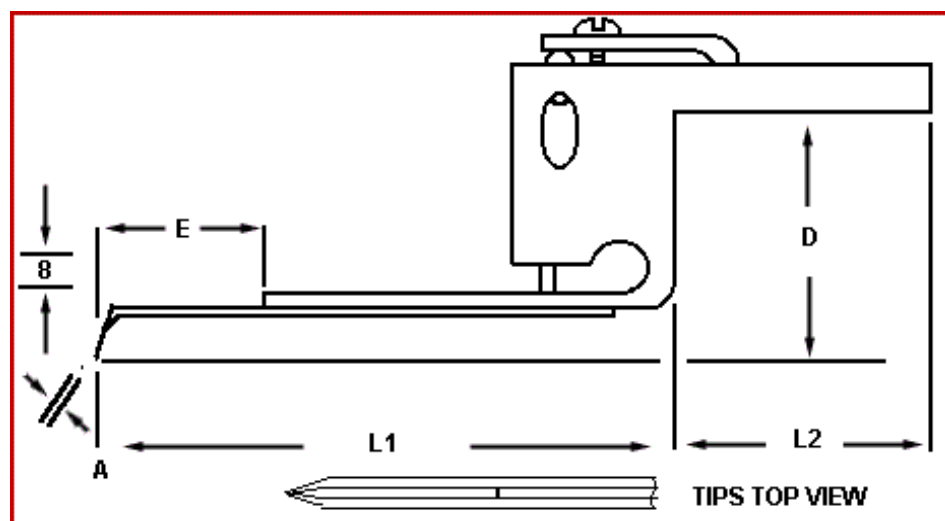

CONCLUSION

Successful probing of GaAs devices is a result of mastering both the mechanical as well as the electrical properties of the probes and the probe cards. It is extremely important that device design engineers, test engineers and the probe card designers work cooperatively to bring about unique solutions in regards to testing the new GaAs devices.

BITA ELECTRONIQUE S.A.

45 Rte d'Arlon
LU-1140 LUXEMBOURG VILLE
Gr. D. Luxembourg
Ph. +352 450010
Fx. +352 332643
info@bita.lu - www.bita.lu

BITA ELEKTRONIK SVENSKA AB

POB 3434
SE-10368 STOCKHOLM
Sweden
Ph. +46 (8) 31 9000
Fx. +46 (8) 326064
info@bita.se - www.bita.se